

MODEL LLE400T (XSZ-801BNT)

BIO-MICROSCOPE

SERVICE MANUAL

Attention

Dear Sir or Madam:

Thank you for using our XSZ-801BN microscope. As one of the professional designers, manufacturers and distributors for optical instruments in China, since 1978, we have been working for supplying the new or old customers worldwide with high-quality and low-cost products. We wish that our products could bring you success and satisfaction. We enjoy offering you the most suitable products and the best service.

This manual gives a minute description of the structure, principle, configuration operating guide, troubleshooting, maintenance and some attention for XSZ-801BN bio-microscope. Please read it carefully before you use, and keep it for long time.

In particular, the following notes must be understood thoroughly and obeyed strictly:

1. Permitted use:

This microscope is just only used for biological microscopy observation. Don't misuse it for other purpose.

2. No dismantle the equipment:

Unless you are a microscopic expert, or there is a special guide about doing so in the manual, please don't dismantle your microscope. Otherwise, it will damage the microscope seriously, and reduce greatly its accuracy and using-life. When you identify some troubles, and can't troubleshoot them by yourself according the manual, please contact us or our representative in you area.

3. Safety

Before change a bulb, or need to open the base, ensure that the microscope has been disconnected with the power source. The new bulb must be the same specifications as the old one.

When the illuminator is halogen lamp or incandescent lamp, the base near the lighting source may be very hot. Don't worry about it, but it must be treated carefully. Please take the combustible material (such as gasoline, paper, plastic and cloth) far away from the microscope.

When change incandescent bulb or halogen bulb, wait until it is cool enough, otherwise the hot bulb will burn your fingers.

4. Use the correct power supply voltage. The power supply voltage must be fitted to the microscope; otherwise it will damage the circuit and bulb, even lead to insecurity.

5. Protecting optical parts

Never try to contact directly the optical surface of objectives, eyepieces and other optical parts with your finger. Fingerprints will seriously affect your observation results.

6. Don't leave any dust and fingerprints on the bulb, otherwise it may affect its life and illuminating efficiency.

7. Working surroundings requirements

Room temperature: 0°C-40°C

The highest relative humidity: 85%

High temperature and humidity can cause mildew and damage the instrument.

8. Microscope is a precision instrument, soft and gentle operation is necessary. Any rude action or hard shake may damage it.

INDEX

A) Application.....	P.1
B) Principle.....	P.1
C) Structure and Specification.....	P.2
1. Eyepiece.....	P.3
2. Objective.....	P.3
3. Mechanical Tube Length.....	P.3
4. Conjugated Distance Between Object and Image.....	P.3
5. Viewing Head.....	P.3
6. Nosepiece.....	P.3
7. Mechanical Stage.....	P.3
8. ABBE Condenser.....	P.4
9. Focusing System.....	P.5
10. Illumination System.....	P.5
D) How to Assemble.....	P.6
E) How to Operate.....	P.6
F) Trouble Shooting.....	P.7
1. Troubles in Operating.....	P.7
2. Troubles in Optical System.....	P.8
3. Troubles in Electric System.....	P.9
G) Maintenance and Care of Your Microscope.....	P.9
H) Electronic Eyepiece Used in Microscope.....	P.9

A) Application:

This series microscope is a high precision instrument designed and produced by our company. It is specially designed for clinical examination and teaching demonstration in medical and health establishments, laboratories, agricultural science and technology field, research institutes. It is used for routine work and research in biology, bacteriology cytology and pharmacology. Providing with some optional accessories, the microscope will be enlarged its functions in demonstrating, collecting, saving and analyzing of the micro-image.

B) Principle:

The principle of the microscope is showed in Fig 1. The lamp (a) illuminates. The light from lamp is introduced to the condenser (b) and then converged on the specimen (c) by the condenser. The image of the specimen(c) is first magnified by the objective (d) and then further magnified by the eyepiece (f). The prism (e) is used to change the direction of the light.

Total magnification= (magnification of objective) multiply (magnification of eyepiece)

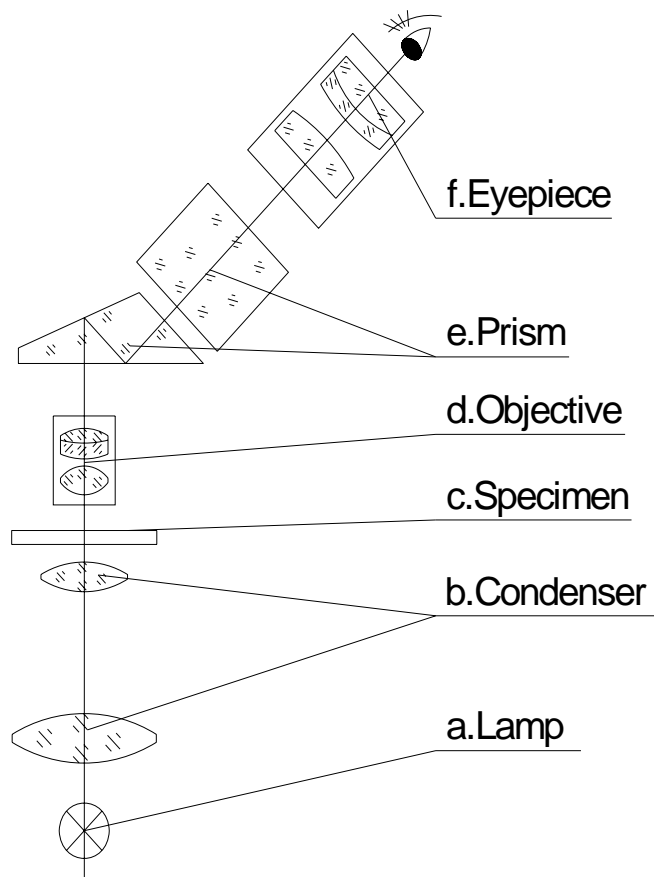
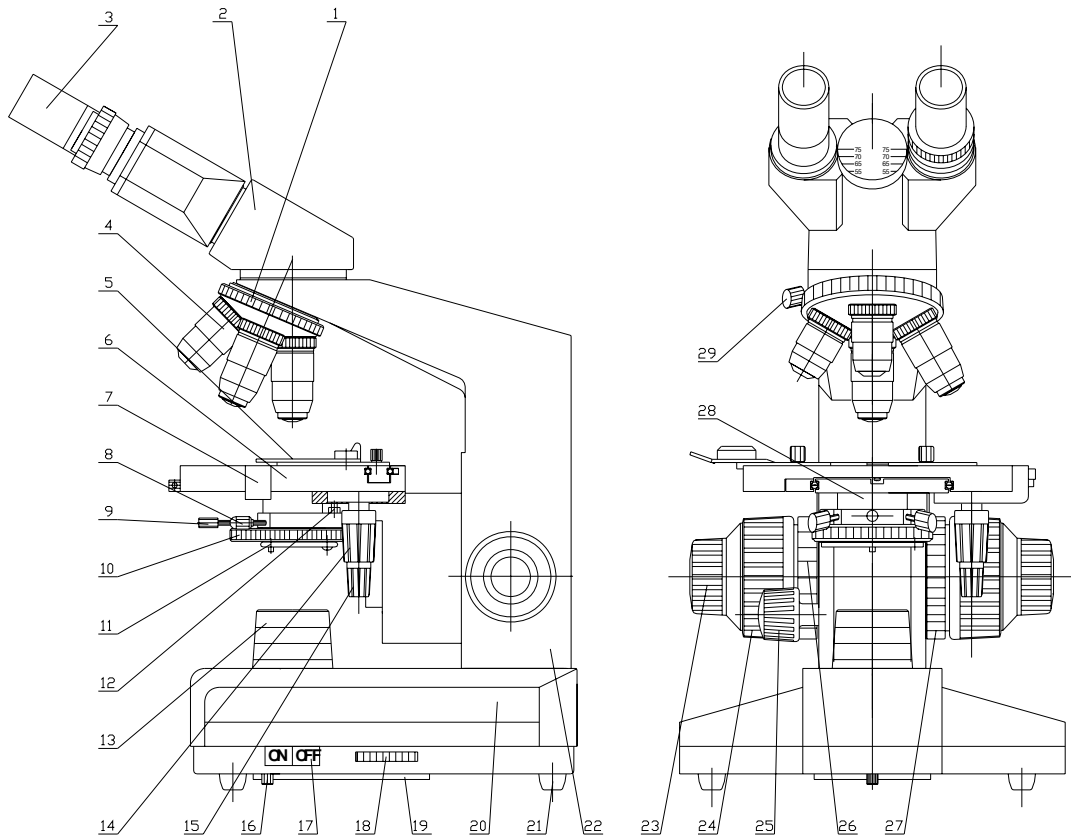

Fig 1.The Principle Draft

C) Structure and main specifications:

The structure of microscope is showed in Fig 2.



- | | | |
|--|---|--|
| 1.Nosepiece | 2.Viewing Head | 3.Eyepiece |
| 4.Objective | 5.Specimen Clamp | 6.Mechanical Stage |
| 7.Vernier for Stage Moving Lengthwise | 8.Screw for Centring the Condenser | 10.Iris Diaphragm Plate |
| 9.Screw for Fixing the Condenser | 12.Screw for Condenser Height | 13.Light Collector |
| 11.Filter Holder | 14.Knob for Moving Stage Lengthwise(Y) | 15.Knob for Moving Stage Crosswise(X) |
| 16.Screw for Bulb Changing | 17.Swtich | 19.Bulb Case |
| 18.Plate for Adjusting Brightness | 20.Base | 21.Rubber Feet |
| 22.Arm | 23.Fine Focusing Knob | 24.Coarse Focusing Knob |
| 25.Knob for Condenser Up or Down | 26.Stage Stop Knob | 27.Focusing Tension Knob |
| 28.ABBE Condenser | 29.Screw for Fixing Viewing Head | |

Fig 2. The Structure Draft

1. Eyepiece (3):

Usually, the microscope is only equipped with wide-field and plano-scope eyepiece WF10X. The specifications of WF10X are showed as following:

Wide Field Plane-scope Eyepiece	Magnification	Diameter of Viewing Field	Working Distance	Remark
WF10X	10	18mm	24.95mm	with point

2. Objective (4):

In this microscope, the standard outfit of the objective system is DIN achromatic objectives which are 4X, 10X, 40X (spring loaded), 100X (spring loaded, oil immersion). The objective 100X is a immersion lens. When the 100X objective is used, between its top and the cover glass, should drop some immersion oil and be sure to make the air bubble out. If there is some air bubble in oil, you may rotate the nosepiece once more, or add more oil again. After finish observing, the top of the objective (100X and 40X) and the cover glass should be cleaned at once. Otherwise the remained dry oil will impair the imaging quality in the next observing.

The specifications of the DIN achromatic objective system are showed as following:

DIN Achromatic Objective	Magnification	Numerical Aperture	Working Distance	Remark
4X	4	0.10mm	36.9mm	
10X	10	0.25mm	7.116mm	
40X	40	0.65mm	0.632mm	Spring
100X	100	1.25mm	0.158mm	Spring, Oil

3. Mechanical tube length: 160mm

4. Conjugated distance between object and image: 195mm.

5. Viewing head (2):

Its viewing head is an articulated free binocular head. It is 30° inclined, and 360° rotatable. Its interpupillary distance is adjustable between (55 – 75) mm, and its diopter can be adjusted in ± 5 diopter on one eyepiece.

6. Nosepiece (1):

The advanced and precise construction of the nosepiece guarantees smooth rotation, clear and positive location, and meets the requirement of par-focal and par-centered objectives.

7. Mechanical stage (6):

The stage of this microscope is double layers mechanical stage showed in Fig 3. Its size is 140(L) X155(W) mm. Push the rod of the clamp in the arrow direction as Fig 3, and insert the specimen into the clamp carefully.

P.3

Leave your finger away from the clamp, the clip will turn back slowly, and the specimen will be held and moved with the clamp. Rotate the knob (14) to move the clamp lengthwise in 50mm. Rotate the knob (15) to move the clamp crosswise in 70mm. The moving precision is 0.1mm in both directions.

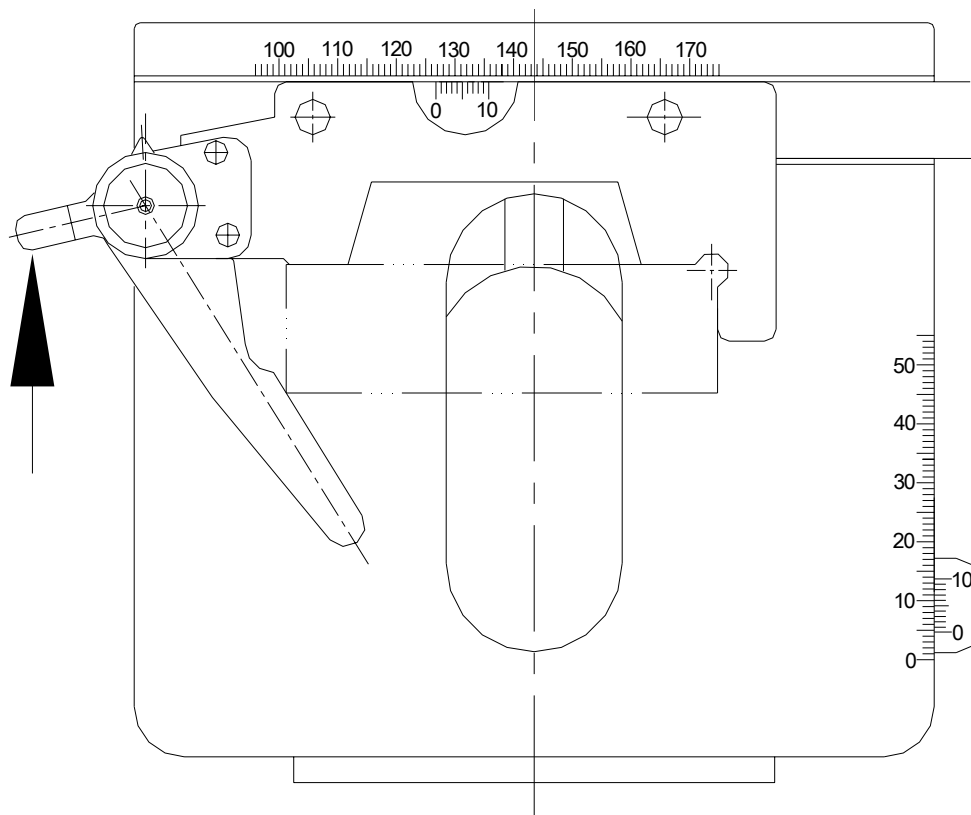

Fig 3. Mechanical Stage

8. ABBE condenser(28) :

The numerical aperture (N.A.) is 1.25. The screw (9) is used to fix the condenser easily without any tools. The center of the condenser in microscope can be adjusted by rotating the black-head screws(8) without any tools as following steps: a)turn the objective 4X or 10X in working; b)turn the plate(10) to make the diaphragm diameter smaller; c)lower the condenser to make the image of the diaphragm sharp by rotating the knob(25); d)rotate the screws (8) to concentre the image of the diaphragm with the eyepiece viewing field. The condenser has been adjusted coaxial with the objective before the microscope leave from our factory. If not, there will be large different in the viewing field: one side may be dark and another side may be bright. Rotate the knob (25), built-in rack and pinion mechanical system controls the condenser up or down to 20mm. Usually, raise the condenser higher when 100X or 40X objective is used; Down the condenser lower when 10X or 4X objective is used. The highest position of the condenser rising up is limited to lower 0.2mm below the stage surface before the microscope is finished. When it is necessary to readjust, please do as following steps:

P.4

- a) Loose the nut on the screw (12);
- b) Put a slide on the stage;
- c) Raise the condenser up to 0.2mm about lower below the slide;
- d) Rotate the screw (12) to touch the bottom of the stage;
- e) Fix the screw (12) with the nut.

Turn the diaphragm plate(10) to adjust the diameter of the iris diaphragm from $\Phi 2$ to $\Phi 30$ mm to match with the numerical aperture of objective in using.

When the diameter of the iris diaphragm is 70-80% of the objective's numerical aperture, the image observed is sharp in contrast. Look into the tube without eyepiece, and you can see the image of the iris diaphragm.

The filter holder (11) can be turned out to insert the filter when you need. The color of the filter may be blue, or green, or yellow.

9. Focusing system:

It is a coaxial coarse and fine focusing system with rack and pinion mechanism. Coaxial coarse and fine focusing system enable you to perform two functions of coarse focusing and fine focusing without moving your hands to a different position. Its focusing range is 25mm, and its precision of fine focusing is 0.002mm. Rotate the coarse focusing knob (24) to raise the stage up or down quickly. Rotate the fine focusing knob (23) to raise the stage up or down slowly.

The stage stop knob (26) prevents the objective and specimen from damage. Loosen the stage stop knob (26) in the anticlockwise direction, and raise the stage (6) up to the limited position by the coarse focusing knob (24), then tension the stage stop knob (26) in the clockwise direction. The limited position of the stage (6) will not be changed if the stage stop knob (26) is not loosed.

The focusing tension knob (27) can adjust the strain of the coarse focusing knobs as the operator's usage. The turning in the clockwise direction will tension the coarse focusing knobs and prevent the stage (6) from dropping down because of its deadweight.

10. Illumination system:

Usually, the illuminator of this microscope is 6V/20W halogen lamp. Turn the plate (18) to adjust the brightness of the lamp. So the image backdrop will be not too bright under the lower-powered objectives, or not too weak under the higher-powered objectives.

The position of the bulb in microscope is very import to the imaging quality. When the lighting centre is not coaxial with the objective, there will be large different in the eyepiece viewing field: one side may be dark and another side may be bright. The bulb has been placed correctly in our factory. When change the bulb, please keep it centering.

Caution:

----Before change a bulb, ensure that the microscope has been

disconnected with the power source.

P.5

----The new bulb must be the same specifications as the old one.

----When the illuminator is halogen lamp, the base near the lighting source may be very hot. Don't worry about it, but it must be treated carefully. Please take the combustible material (such as gasoline, paper, plastic and cloth) far away from the microscope.

----When change the halogen bulb, wait until it is cool enough, otherwise the hot bulb will burn your fingers.

----Don't leave any dust and fingerprints on the bulb; otherwise it may affect its life and illuminating efficiency.

Loose the screw (16) under the bottom, open the case (19) to change the bulb.

D) How to assemble:

1. Unpack the microscope and its parts carefully. Check and sort out all parts according to the packing list;

2. For the convenience of packaging and delivering, the components and parts may be separated from the mainframe. Before using, please assemble them together according to the structure draft (Fig 2).

1) Install the viewing head (2):

The viewing head (2) of the microscope is usually separated from the mainframes. Loose the screw (29) and take off the plastic plate cover on the arm (22). Take off the plastic plate cover on the viewing head. Finally install the viewing head on the arm (22) and fix it with the screw (29). Don't try to loose another two screws in the arm for centering the viewing head.

2) Install the objectives (4):

Usually, the objectives are fixed stably on the nosepiece by us. Sometimes, they are separated from the mainframe. Screw the plastic dust cover out off the nosepiece (1) and take the objectives out off plastic bottles. Screw them on the nosepiece (1) by their magnification order from low to high.

3) Install the eyepiece (3):

Take off the plastic dust cover from the eyepiece tube and insert the eyepiece needed.

E) How to operate:

1) Select a position to work where little direct light falls on the instrument. Keep the microscope far away from a large window and not to face the window, because the direct light may adversely affect the contrast and resolution of the image.

The following working surroundings are required

a) Room temperature: 0°C-40°C; The highest relative humidity: 85%

b) High temperature and humidity can cause mildew and damage the instrument.

c) Keep the microscope away from dust. When it is not used, put the dust cover over it.

d) Keep the microscope away from vibration.

2) Insert the micro-slide specimen into the clamp (5). Be sure that the

P.6

cover glass is facing towards the objective. Otherwise you will not be able to focus your specimen at using higher powered objective (40X, or 100X).

3) Place a lower powered objective (4X, or 10X) into position and simply turn on the illuminator.

Caution: The power supply voltage must be fitted to the microscope; otherwise it will damage the circuit and bulb, even lead to insecurity.

4) Rotate the knobs (14, 15) to move the specimen so that it is centered over the in-stage condenser.

5) Focus the objective on the specimen by turning the coarse focusing knob (24) until the image is bright and clear. You can find the focal plane and focusing upwards by using the lower powered objective, and then you can bring the specimen into sharp focus by turning the fine focusing knob (23).

6) The specimen now is in sharp focus. Rotate the nosepiece (1) to the other objectives and focus using only the fine focusing knob (23). Since the optics on the microscopes are Par-focal and Par-centered, only slightly turn the fine focusing knob (23) to make the image bright and clear.

Note: It is important to note that the 4X and 10X objectives can never come into contacting with your micro-slide specimen because of our built-in stop. The 40X and 100X objectives may occasionally touch the micro-slide specimen. But because they have retractable mounts, the micro-slide specimen will not be damaged.

7) To make the image clearer, you can adjust diameters of the iris diaphragm to match with the numerical aperture of objective in use (**Section 8. ABBE condenser in P.4**).

F) Trouble Shooting:

If there are some troubles in operating, recheck the instrument carefully as the following describing before connect us or our representative in you area.

1. Troubles in operating:

Troubles	Causes	Remedies
The specimen goes out of focus.	The stage is limited too low.	Adjust the the upper focusing limit.
The slide is often broken by objective	The stage is limited too high.	Adjust the the upper focusing limit.
Can't focus in using high powered objective.	The specimen is mounted on the stage upside down or the cover glass is too thick.	Reverse the specimen or choose the standard cover glass(0.17mm).
The objective always touches with the slide when changing.	The cover glass is too thick.	Choose the standard cover glass (0.17mm).
Move the specimen no smoothly.	The clamp is not fixed stably.	Fix the clamp stably on the stage.
Incomplete binocular vision.	Interpupillary distance is not correctly adjusted.	Correct the interpupillary distance .
	Dioper adjusting is incomplete.	Complete the dioper adjusting.
	The brightness is not suitable.	Checkthe illuminator and adjust its brightness.

P.7

2. Troubles in optical system:

Troubles	Causes	Remedies
Field of view is cut off, or illuminated irregularly.	The nosepiece is not changed properly.	Slightly rotate the nosepiece until it clicks into position.
	The centre of the bulb is not coincidence with the centre of the objective.	Position the bulb correctly.
	There are dust or dirt on the glass surface of the lenses.	Remove the dust and dirt.
Dust and dirt is visible in the field of view.	There are dust or dirt on the glass surface of the lenses.	Remove the dust and dirt.
	There are dust or dirt on the specimen surface.	Remove the dust and dirt.
	The condenser is too low.	Raise the condenser up.
Image quality is poor: insufficient contrast and image details lack definition.	There is no cover glass on the slide.	Put the cover glass on the slide.
	The cover glass is too thick or thin.	Choose the cover glass 0.17mm thick.
	The specimen is mounted on the stage upside down.	Reverse the specimen.
	The top lens of the objective is dirty.	Clean it.
	There are dust or dirt on the glass surface of the lenses.	Remove the dust and dirt.
	Immersion objective is used without immersion oil.	Apply immersion oil.
	There are bubbles in the immersion oil.	Drive the bubbles out.
	Special immersion oil is not used.	Use the special immersion oil.
	There are dust or dirt on the surface of the prisms.	Remove the dust and dirt.
	The diameter of the iris diaphragm is too large or small.	Adjust the diameter of the iris diaphragm.
The condenser is too low.	Raise the condenser up.	
One side of the viewing field is dark.	The condenser is not correctly positioned in the light path or inclined.	Position the condenser.
	The objective is not correctly positioned in the light path.	Slightly rotate the nosepiece until it clicks into position.
	The clamp is not fixed stably.	Fix the clamp stably on the stage.
Image moves while focusing	The specimen is not caught stably by the clamp.	Catch the specimen stably.
	The objective is not correctly positioned in the light path.	Slightly rotate the nosepiece until it clicks into position.
The image is yellow.	Blue filter is not used.	Apply the blue filter.
The viewing field is too dark.	The diameter of the iris diaphragm is too small.	Adjust the diameter of the iris diaphragm larger.
	The condenser is too low.	Raise the condenser up.
	There are dust or dirt on the glass surface of the lenses.	Remove the dust and dirt.

3. Troubles in electric system:

Troubles	Causes	Remedies
The bulb does not light when turn on.	Loose electric connection.	Secure the connection.
	No insert the bulb.	Insert the bulb correctly.
	Fuse is burned out.	Replace the bulb.
	Fuse is burned out.	Replace the fuse.
Reduced bulb life.	Bulb is not a standard one.	Use a standard bulb.
	Bulb is voltolized.	Reduce bulb voltage.
Illuminator is too dark.	Bulb is not a standard one.	Use a standard bulb.
	Mains voltage is too low..	Adiust the mains voltage.
Light flickers and the intensity is unstable.	Mains voltage is unstable.	Use a voltage stabilizer.
	Bulb's filament is likely to burn out.	Replace the bulb.
	Loose electric connection.	Secure the connection.

G) Maintenance and care of your microscope:

1. Unpack the microscope carefully to prevent the accessories as lenses from falling down and damaging.
2. All lenses are calibrated; don't try to dismantle them apart by yourself.
3. Nosepiece and focusing system is advanced and precise in construction, and don't try to dismantle them apart by yourself. Please connect with an authorized technician when they are in trouble.
4. Keep the mechanical parts from dust, and add no corrosiveness lubricating grease into the sliding sections at regular intervals. Keep the optical elements clean when wipe the instrument.
5. Keep the instrument in dry and cool place. Disconnect it with the power source and put the dust cover over it after use.

H) Electronic eyepiece used in microscope:

When the electronic eyepiece is needed to use, please take one eyepiece out of the tube and insert the electronic eyepiece in. Run the software and open the camera, you can observe the micro-image in the PC screen.

See Fig. 4, and connect the camera with the microscope as following steps:

1) Prepare a PC required:

Hardware: USB2.0 Connecting Socket; CPU: Intel P4; EMS Memory: 256M

Hard Disk: 512M; PC Screen Resolution: 1024*768

Software: Windows XP or Windows Vista;

2) Insert the driver CD into your PC and run the installing program and as the prompting information;

Setup the application software. The files in CD will tell you how to install this software and guide you how to use the application software.

P.9

3) Prepare the microscope for using. Insert the electronic eyepiece into the microscope tube, and connect it correctly with your PC;

4) Adjust the microscope in the best working state according to the manual and find a clear image in the eyepiece viewing field. Wait a moment, the micro-picture will be showed in the PC screen. Focus slightly by the fine focusing knob and adjust the position of the condenser and the diameter of the iris diaphragm to make the picture clearer.

Generally, when low-powered objective (4X or 10X) is used, the picture in the PC screen will be too bright to observe, you can: 1) Darker the illuminator; 2) Smaller the diameter of the iris diaphragm; 3) Lower the ABBE condenser.

When high-powered objective (40X or 100X) is used, the picture in the PC screen will be too dark to observe, you can: 1) Bright the illuminator; 2) larger the diameter of the iris diaphragm; 3) Higher the ABBE condenser.

The application software is user-friendly sophisticated micro-image process software to help you for previewing, measuring, comparing, counting, saving and deleting.

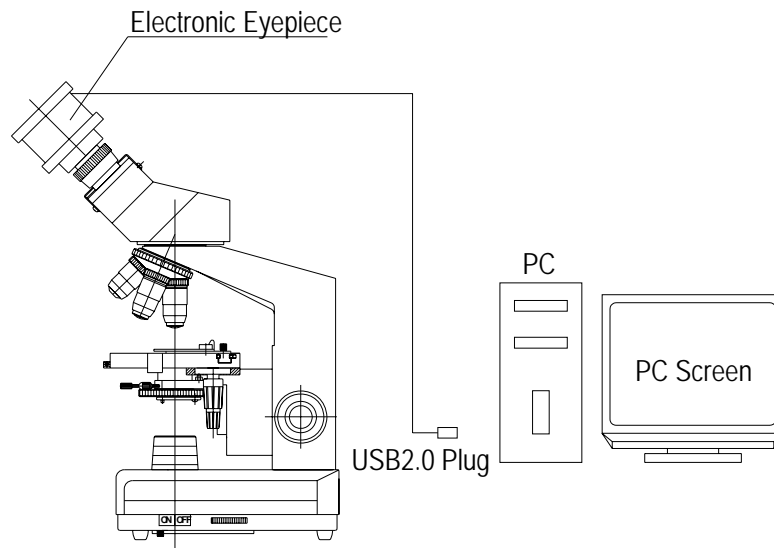

Fig 4. Microscope with Electron Eyepiece